

## Structural

Description	CID	Cut Type	Pat Gp
Angle Equal	910	Draw Only	Rectangular/Standard
Angle Unequal	910	Draw Only	Rectangular/Standard
Box Section Square	910	Draw Only	Rectangular/Standard
Box Section Unequal	910	Draw Only	Rectangular/Standard
Channel	910	Draw Only	Rectangular/Standard
Circular Hollow Section	910	Draw Only	Rectangular/Standard
Joists	910	Draw Only	Rectangular/Standard
Universal Beam Tee	910	Draw Only	Rectangular/Standard
Universal Beam	910	Draw Only	Rectangular/Standard
Universal Bearing Pile	910	Draw Only	Rectangular/Standard
Universal Column Tee	910	Draw Only	Rectangular/Standard
Universal Column	910	Draw Only	Rectangular/Standard
PF Channel	910	Draw Only	Rectangular/Standard
Unistrut	910	Draw Only	Rectangular/Standard



**Dims**

A=Depth  
 B=Width  
 C=Height  
 D=Flange  
 E=Flange  
 F=Radius  
 G=Radius  
 H=Web  
 I=Angle  
 J=Angle  
 K=Angle  
 L=Angle  
 M=Turnover  
 N=Turnover  
 O=Hole Inset  
 P=Hole Offset  
 Q=Hole Width  
 R=Hole Depth  
 S=Hole Spacing  
 T=Number Of Holes

**Options**

Type  
 Rotation  
 Closed  
 Hole Type  
 Draw as Single Line  
 Full

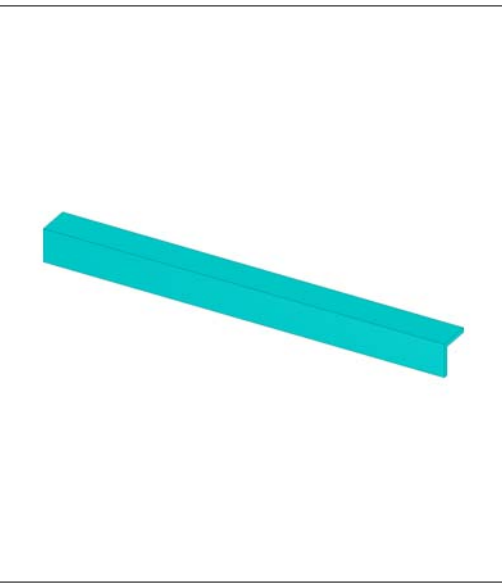

Conn's	Seams
C1 C2	

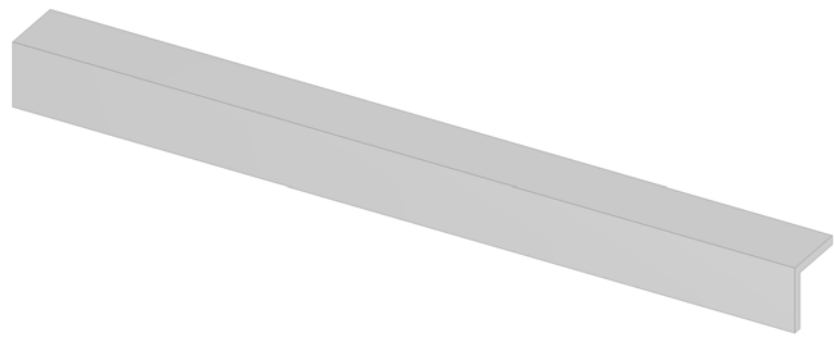

		<p style="text-align: center;">Dims</p> <p>A=Depth                  B=Width                  C=Height                  D=Flange                  E=Flange                  F=Radius                  G=Radius                  H=Web                  I=Angle                  J=Angle                  K=Angle                  L=Angle                  M=Turnover                  N=Turnover                  O=Hole Inset                  P=Hole Offset                  Q=Hole Width                  R=Hole Depth                  S=Hole Spacing                  T=Number Of Holes</p>	
		<p style="text-align: center;">Options</p> <p>Type                  Rotation                  Closed                  Hole Type                  Draw as Single Line                  Full</p>	
		<p style="text-align: center;">Conn's</p> <p>C1                  C2</p>	<p style="text-align: center;">Seams</p>

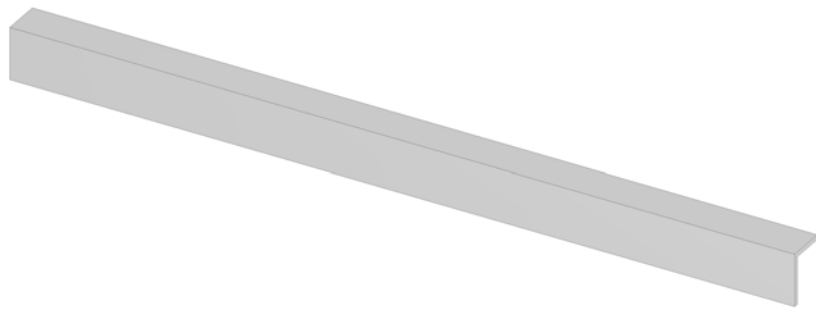

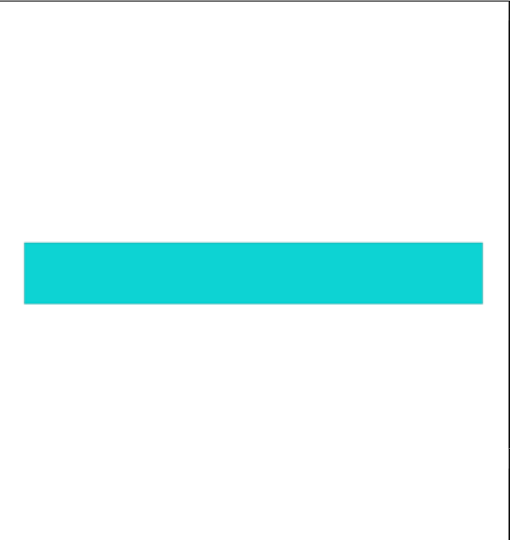
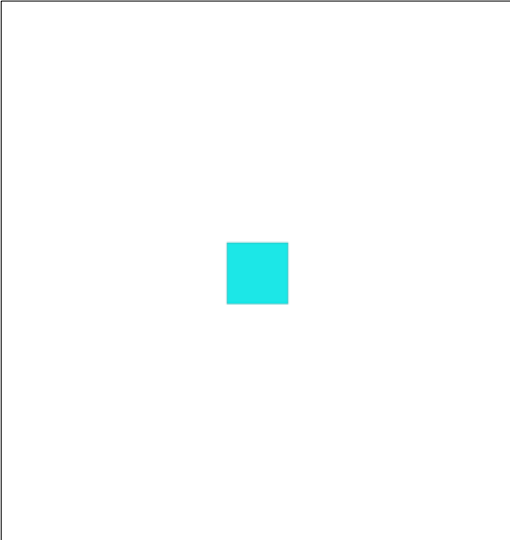

**Dims**

A=Depth  
 B=Width  
 C=Height  
 D=Flange  
 E=Flange  
 F=Radius  
 G=Radius  
 H=Web  
 I=Angle  
 J=Angle  
 K=Angle  
 L=Angle  
 M=Turnover  
 N=Turnover  
 O=Hole Inset  
 P=Hole Offset  
 Q=Hole Width  
 R=Hole Depth  
 S=Hole Spacing  
 T=Number Of Holes

**Options**

Type  
 Rotation  
 Closed  
 Hole Type  
 Draw as Single Line  
 Full

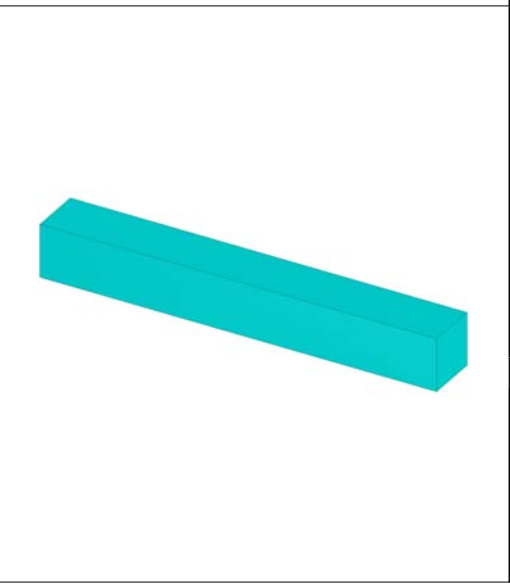
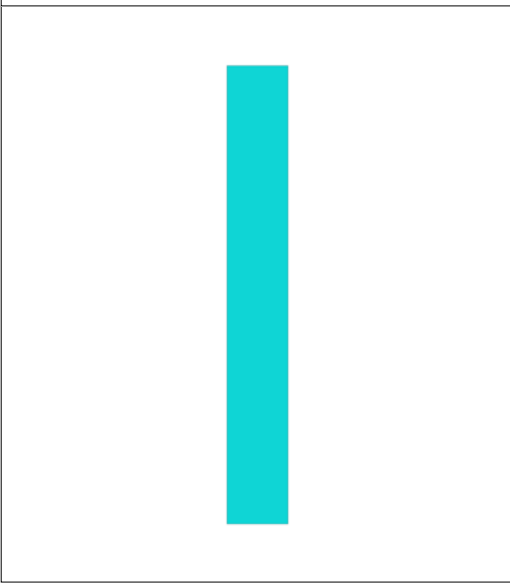

<b>Conn's</b>		<b>Seams</b>	
C1			
C2			

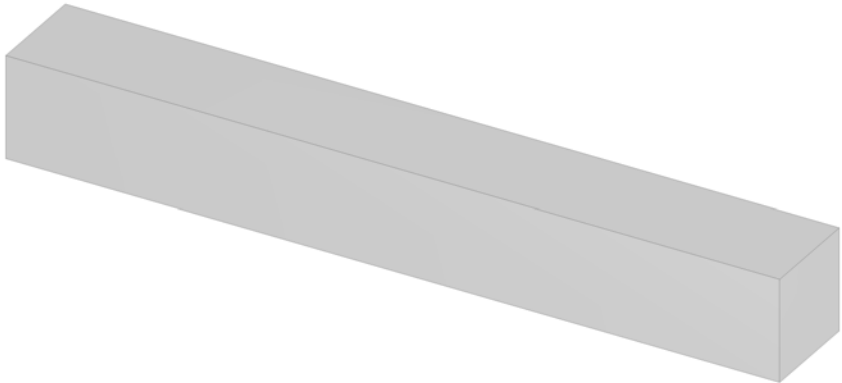

		<p style="text-align: center;"><b>Dims</b></p> <p>A=Depth          B=Width          C=Height          D=Flange          E=Flange          F=Radius          G=Radius          H=Web          I=Angle          J=Angle          K=Angle          L=Angle          M=Turnover          N=Turnover          O=Hole Inset          P=Hole Offset          Q=Hole Width          R=Hole Depth          S=Hole Spacing          T=Number Of Holes</p>	
		<p style="text-align: center;"><b>Options</b></p> <p>Type          Rotation          Closed          Hole Type          Draw as Single Line          Full</p>	
		<p style="text-align: center;"><b>Conn's</b></p> <p>C1          C2</p>	<p style="text-align: center;"><b>Seams</b></p>

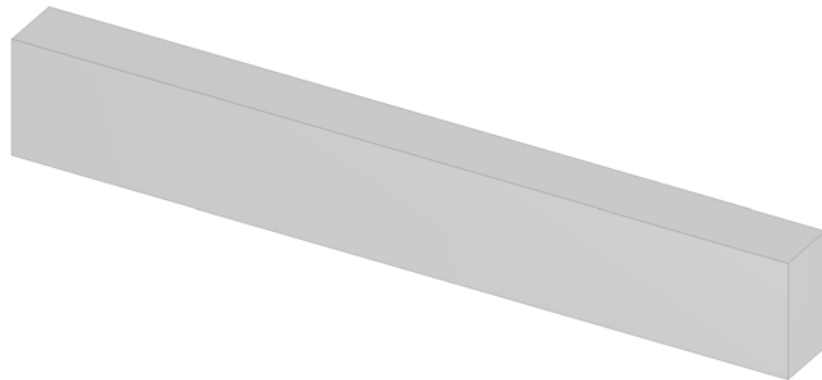

		<p style="text-align: center;"><b>Dims</b></p> <p>A=Depth          B=Width          C=Height          D=Flange          E=Flange          F=Radius          G=Radius          H=Web          I=Angle          J=Angle          K=Angle          L=Angle          M=Turnover          N=Turnover          O=Hole Inset          P=Hole Offset          Q=Hole Width          R=Hole Depth          S=Hole Spacing          T=Number Of Holes</p>	
		<p style="text-align: center;"><b>Options</b></p> <p>Type          Rotation          Closed          Hole Type          Draw as Single Line          Full</p>	
		<p style="text-align: center;"><b>Conn's</b></p> <p>C1          C2</p>	<p style="text-align: center;"><b>Seams</b></p>

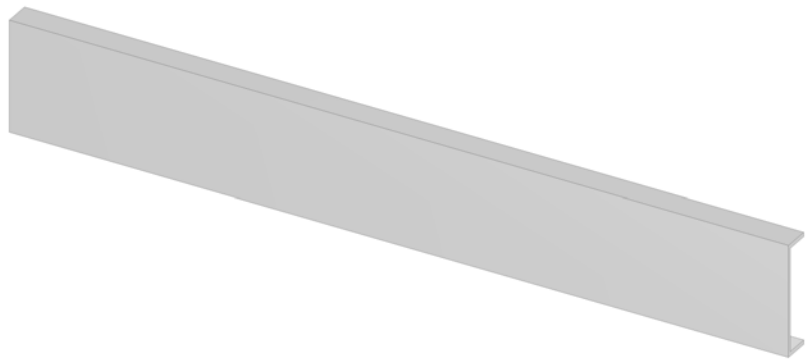

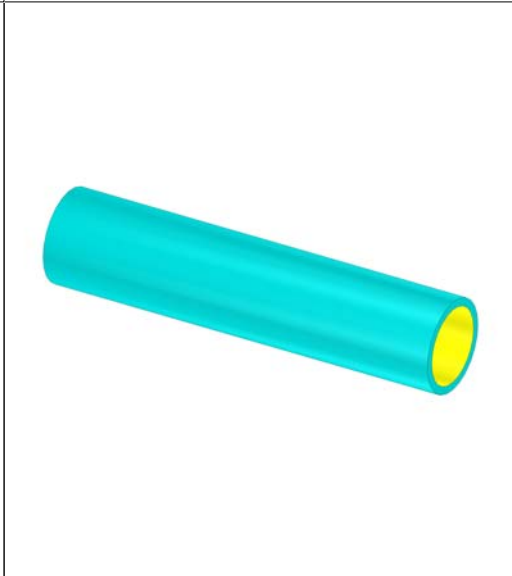
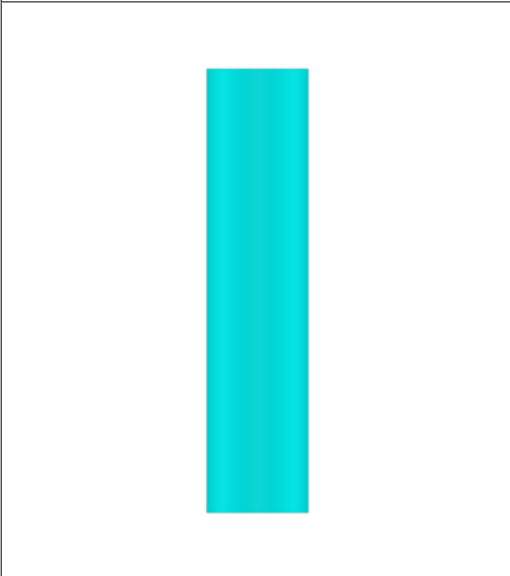
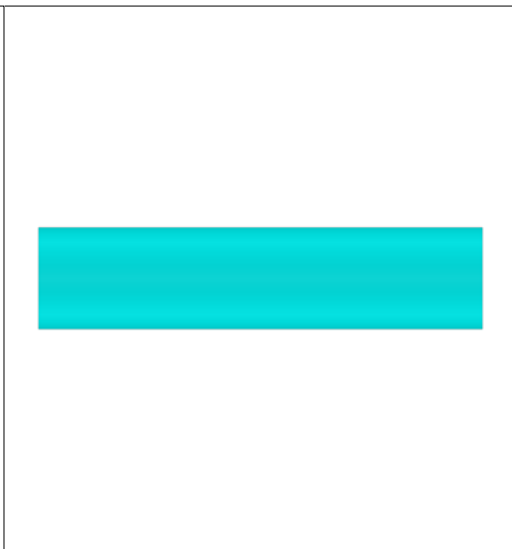
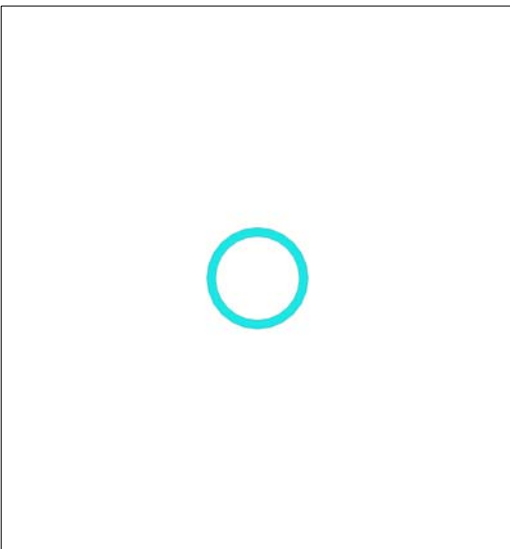



Dims	
A=Diameter	
B=Width	
C=Height	
D=Flange	
E=Flange	
F=Radius	
G=Radius	
H=Web	
I=Angle	
J=Angle	
K=Angle	
L=Angle	
M=Turnover	
N=Turnover	
O=Hole Inset	
P=Hole Offset	
Q=Hole Width	
R=Hole Depth	
S=Hole Spacing	
T=Number Of Holes	



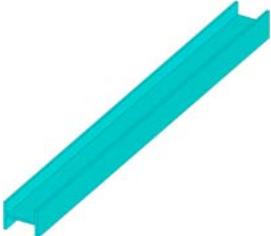

Options	
Type	
Rotation	
Closed	
Hole Type	
Draw as Single Line	
Full	

Conn's	Seams
C1	
C2	

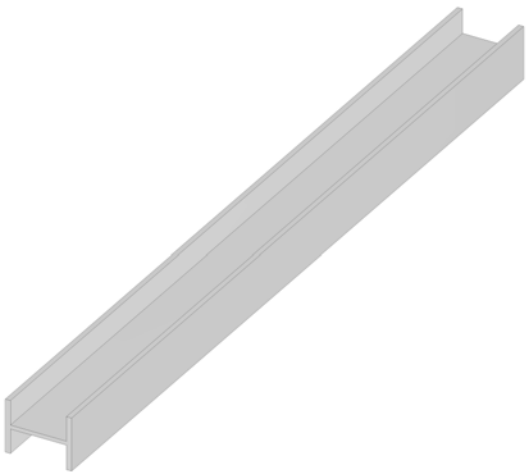



		<p style="text-align: center;"><b>Dims</b></p> <p>A=Depth                  B=Width                  C=Height                  D=Flange                  E=Flange                  F=Radius                  G=Radius                  H=Web                  I=Angle                  J=Angle                  K=Angle                  L=Angle                  M=Turnover                  N=Turnover                  O=Hole Inset                  P=Hole Offset                  Q=Hole Width                  R=Hole Depth                  S=Hole Spacing                  T=Number Of Holes</p>	
		<p style="text-align: center;"><b>Options</b></p> <p>Type                  Rotation                  Closed                  Hole Type                  Draw as Single Line                  Full</p>	
		<b>Conn's</b>	<b>Seams</b>
		C1 C2	

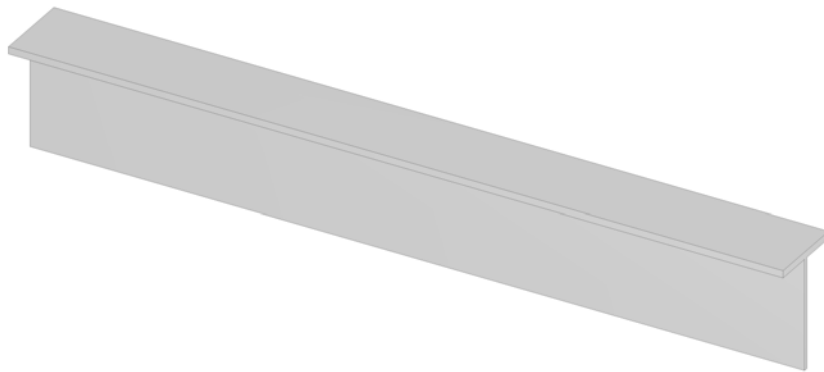

		<p style="text-align: center;">Dims</p> <p>A=Depth          B=Width          C=Height          D=Flange          E=Flange          F=Radius          G=Radius          H=Web          I=Angle          J=Angle          K=Angle          L=Angle          M=Turnover          N=Turnover          O=Hole Inset          P=Hole Offset          Q=Hole Width          R=Hole Depth          S=Hole Spacing          T=Number Of Holes</p>	
		<p style="text-align: center;">Options</p> <p>Type          Rotation          Closed          Hole Type          Draw as Single Line          Full</p>	
		<p style="text-align: center;">Conn's</p> <p>C1          C2</p>	<p style="text-align: center;">Seams</p>



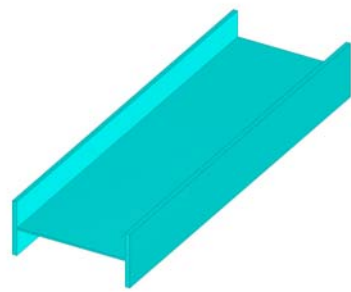

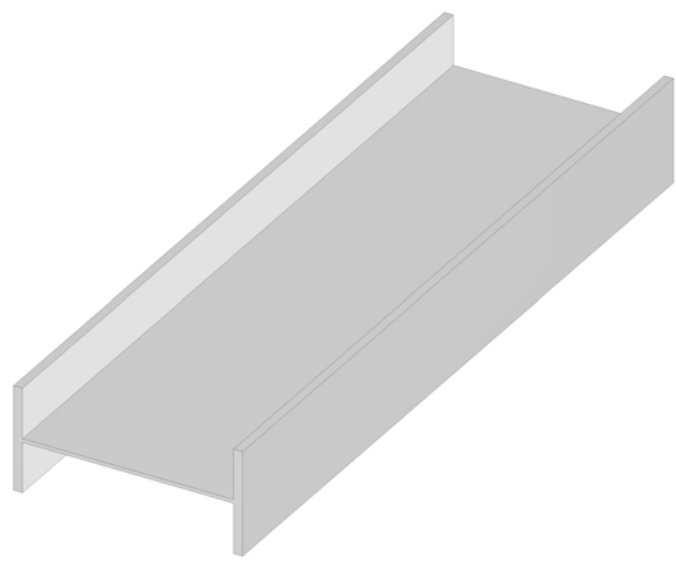
		<p style="text-align: center;"><b>Dims</b></p> <p>A=Depth          B=Width          C=Height          D=Flange          E=Flange          F=Radius          G=Radius          H=Web          I=Angle          J=Angle          K=Angle          L=Angle          M=Turnover          N=Turnover          O=Hole Inset          P=Hole Offset          Q=Hole Width          R=Hole Depth          S=Hole Spacing          T=Number Of Holes</p>	
		<p style="text-align: center;"><b>Options</b></p> <p>Type          Rotation          Closed          Hole Type          Draw as Single Line          Full</p>	
		<p style="text-align: center;"><b>Conn's</b></p> <p>C1          C2</p>	<p style="text-align: center;"><b>Seams</b></p>



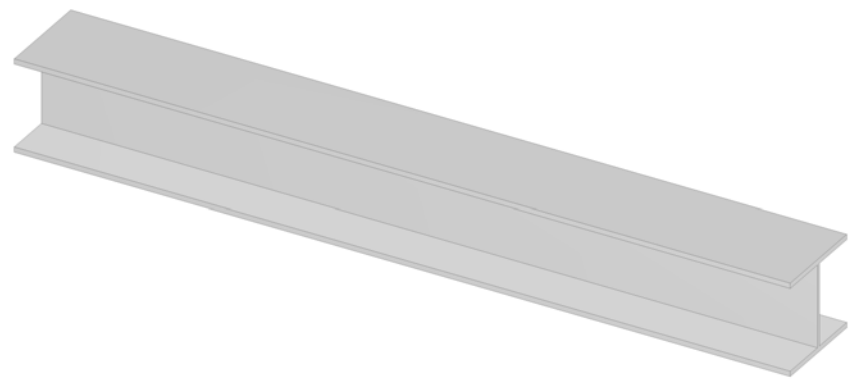

		<p style="text-align: center;"><b>Dims</b></p> <p>A=Depth          B=Width          C=Height          D=Flange          E=Flange          F=Radius          G=Radius          H=Web          I=Angle          J=Angle          K=Angle          L=Angle          M=Turnover          N=Turnover          O=Hole Inset          P=Hole Offset          Q=Hole Width          R=Hole Depth          S=Hole Spacing          T=Number Of Holes</p>	
		<p style="text-align: center;"><b>Options</b></p> <p>Type          Rotation          Closed          Hole Type          Draw as Single Line          Full</p>	
		<p style="text-align: center;"><b>Conn's</b></p> <p>C1          C2</p>	<p style="text-align: center;"><b>Seams</b></p>

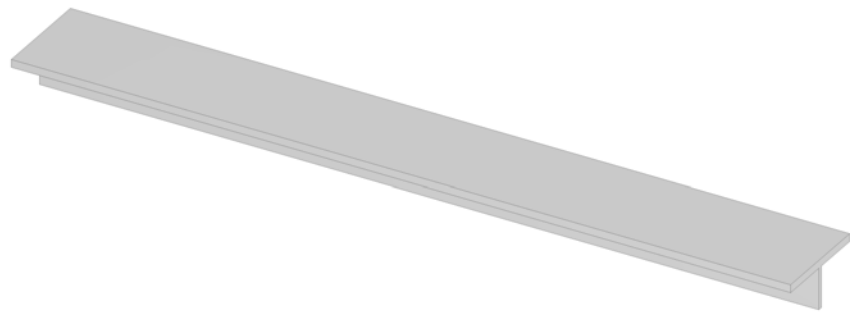

		<p style="text-align: center;"><b>Dims</b></p> <p>A=Depth          B=Width          C=Height          D=Flange          E=Flange          F=Radius          G=Radius          H=Web          I=Angle          J=Angle          K=Angle          L=Angle          M=Turnover          N=Turnover          O=Hole Inset          P=Hole Offset          Q=Hole Width          R=Hole Depth          S=Hole Spacing          T=Number Of Holes</p>	
		<p style="text-align: center;"><b>Options</b></p> <p>Type          Rotation          Closed          Hole Type          Draw as Single Line          Full</p>	
		<p style="text-align: center;"><b>Conn's</b></p> <p>C1          C2</p>	<p style="text-align: center;"><b>Seams</b></p>

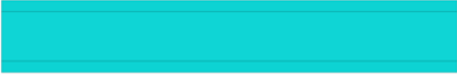

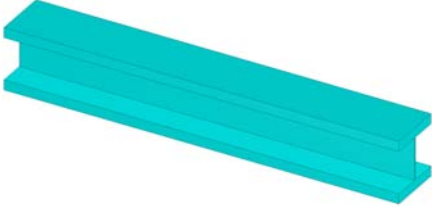
		<p style="text-align: center;"><b>Dims</b></p> <p>A=Depth          B=Width          C=Height          D=Flange          E=Flange          F=Radius          G=Radius          H=Web          I=Angle          J=Angle          K=Angle          L=Angle          M=Turnover          N=Turnover          O=Hole Inset          P=Hole Offset          Q=Hole Width          R=Hole Depth          S=Hole Spacing          T=Number Of Holes</p>	
		<p style="text-align: center;"><b>Options</b></p> <p>Type          Rotation          Closed          Hole Type          Draw as Single Line          Full</p>	
		<p style="text-align: center;"><b>Conn's</b></p> <p>C1          C2</p>	<p style="text-align: center;"><b>Seams</b></p>

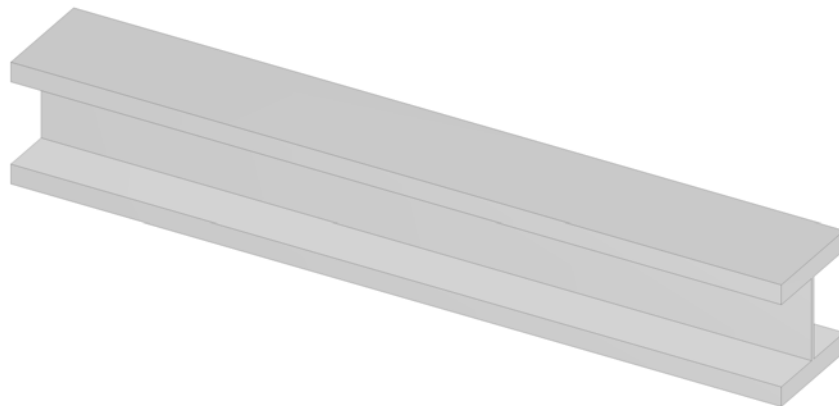

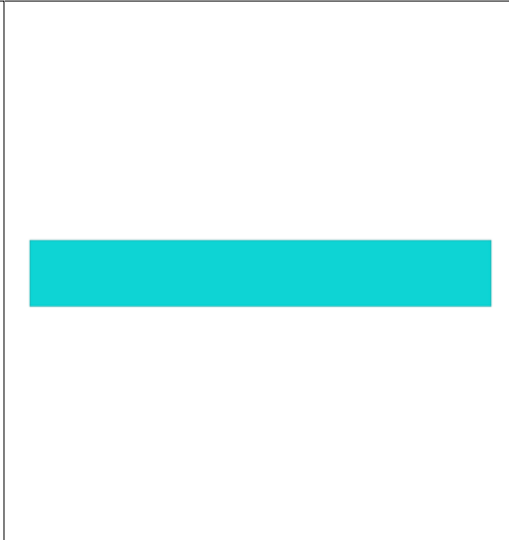
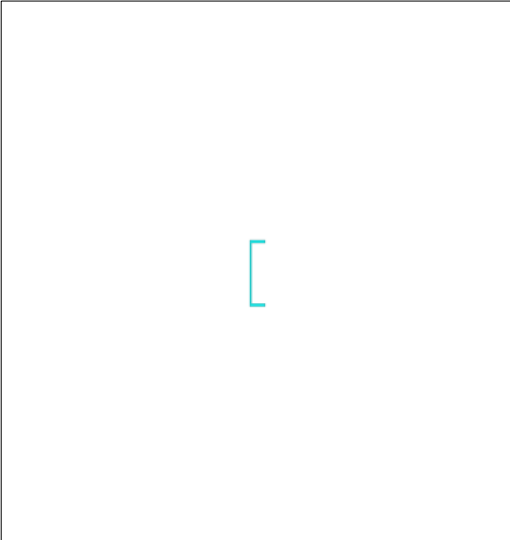

**Dims**

A=Depth  
 B=Width  
 C=Height  
 D=Flange  
 E=Flange  
 F=Radius  
 G=Radius  
 H=Web  
 I=Angle  
 J=Angle  
 K=Angle  
 L=Angle  
 M=Turnover  
 N=Turnover  
 O=Hole Inset  
 P=Hole Offset  
 Q=Hole Width  
 R=Hole Depth  
 S=Hole Spacing  
 T=Number Of Holes

**Options**

Type  
 Rotation  
 Closed  
 Hole Type  
 Draw as Single Line  
 Full

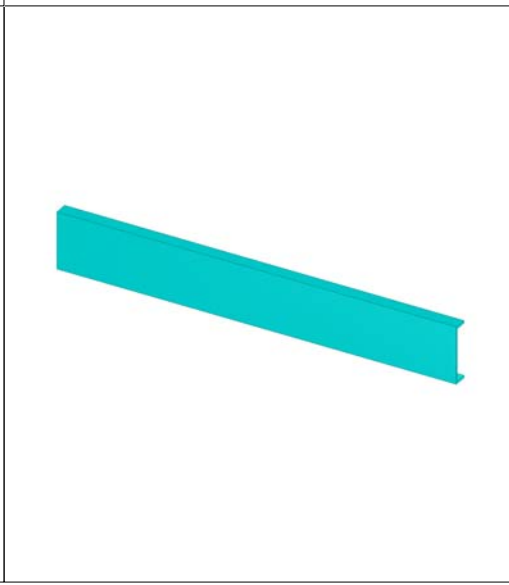
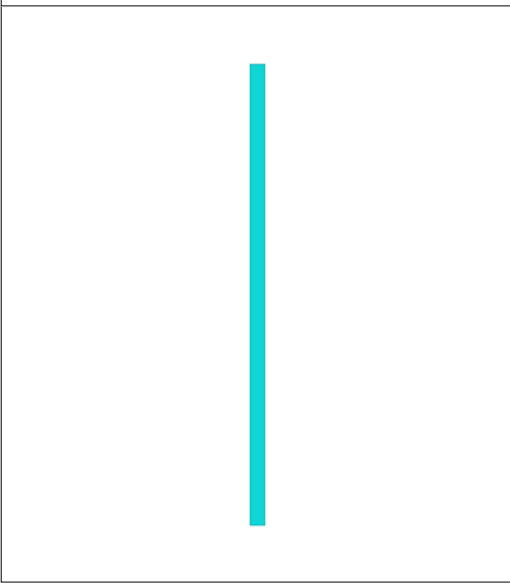

Conn's	Seams
C1 C2	

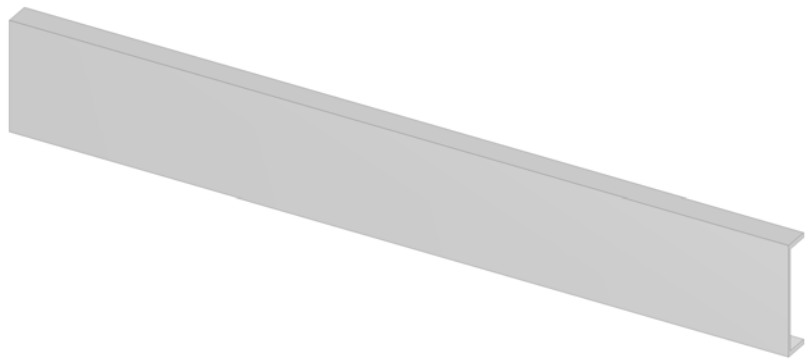

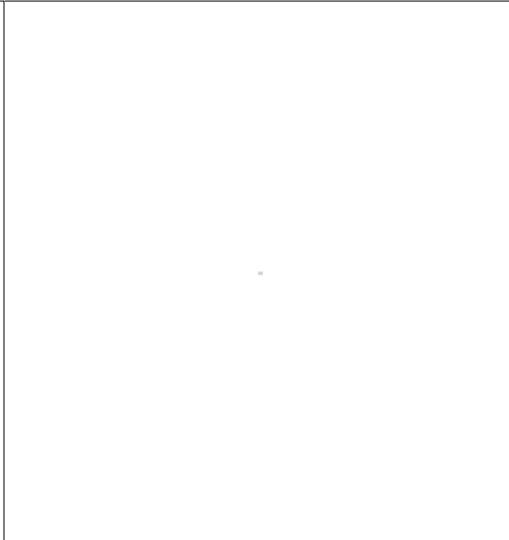
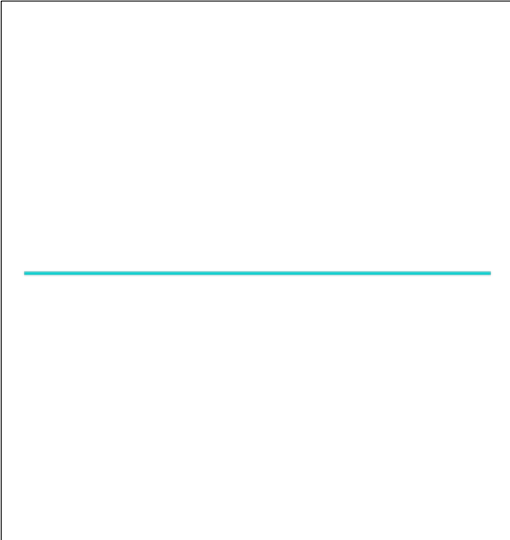

**Dims**  
A=Depth  
B=Width  
C=Height  
D=Flange  
E=Flange  
F=Radius  
G=Radius  
H=Web  
I=Angle  
J=Angle  
K=Angle  
L=Angle  
M=Turnover  
N=Turnover  
O=Hole Inset  
P=Hole Offset  
Q=Hole Width  
R=Hole Depth  
S=Hole Spacing  
T=Number Of Holes

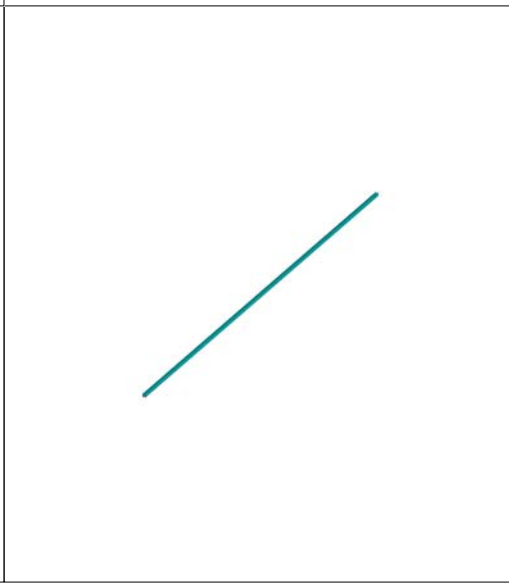
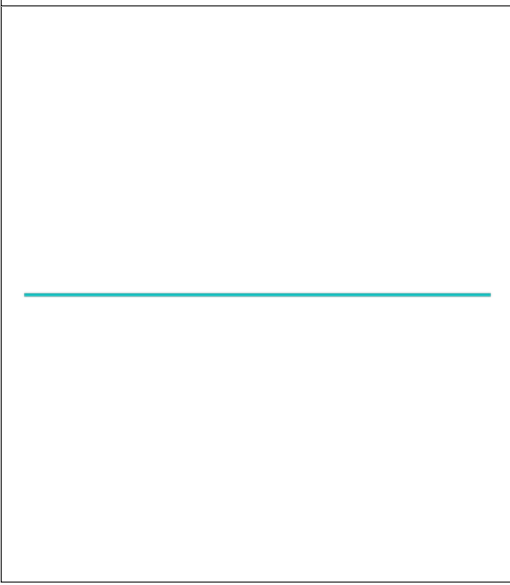

**Options**  
Type  
Rotation  
Closed  
Hole Type  
Draw as Single Line  
Full

**Conn's**  
C1  
C2

**Seams**

